

POLYVANTIS

# TRANSPARENT NOISE BARRIER SOLUTIONS

WITH LEXAN™ POLYCARBONATE SHEET



LEXAN™ SHEET

# CONTENT

<b>POLYVANTIS</b>	<b>04</b>
<b>ABOUT LEXAN™ POLYCARBONATE SHEET</b>	<b>05</b>
<b>INTRODUCTION</b>	<b>06</b>
WHAT ARE NOISE BARRIERS?	06
THE IMPORTANCE OF NOISE BARRIERS	06
NOISE BARRIERS STANDARDS	07
LEXAN™ SHEET FOR ACOUSTIC ELEMENTS	07
<b>PRODUCT SOLUTIONS</b>	<b>08</b>
LEXAN™ SHEET ACOUSTIC PERFORMANCE	08
LEXAN™ SHEET NON-ACOUSTIC PERFORMANCE	09
LEXAN™ SHEET BENEFICIAL FEATURES	10
PRODUCT COMPARISON	11
PRODUCT AVAILABILITY	11
<b>PROJECT REFERENCES</b>	<b>12</b>
<b>CONCEPTS &amp; INSTALLATION</b>	<b>15</b>
FREEDOM OF DESIGN	15
DESIGN CONCEPTS	16
INSTALLATION GUIDELINES	18
<b>LOCAL SERVICES &amp; SUPPLY</b>	<b>19</b>



# POLYVANTIS

POLYVANTIS business offers high quality, engineered thermoplastic sheet and film products across a wide variety of industries, ranging from building and construction, consumer electronics, aircraft and rail-interiors to displays. Our LEXAN™ polycarbonate film & sheet portfolio is backed by advanced technical support and application development services around the world to meet our customers' global specification needs with local supply.

At POLYVANTIS, we are dedicated to meeting our customers' ever-changing needs with our unique high performance LEXAN film and sheet portfolio. Through our services and product portfolio, we help our customers to reduce system costs, create innovative designs with better functionality and develop environmentally responsible applications.

# ABOUT LEXAN™ POLYCARBONATE SHEET

POLYVANTIS's LEXAN™ polycarbonate sheet products are directly extruded from LEXAN™ resin, which is a polycarbonate material, and offer significant advantages over many other glazing materials in terms of design freedom, light-weight, fire performance, UV protection and thermal insulation. LEXAN™ polycarbonate sheet combines high impact resistance with optical clarity, thus providing superior safety and security against vandalism and intrusion.

In sound wall and noise barrier applications, LEXAN polycarbonate sheet provides opportunities for highly effective, unobtrusive sound screens with large glazing panels. Our products provides high impact resistance over a wide temperature range, helping to minimize the risk of damage by accidents or vandalism. Due to its long-term UV

protection on both sides, also LEXAN sheet is highly resistant to yellowing and loss of performance due to weathering and virtually doesn't contribute to the spread of fire and the generation of toxic gases. Also it is easy to transport and install on-site with conventional metal working tools.

Renewing the façade of Aviva Stadium , Dublin, Ireland with transparent and acoustic LEXAN™ EXELL™ D Sheet



# INTRODUCTION

## WHAT ARE NOISE BARRIERS?

A noise barrier (sound wall, sound barrier, or acoustical barrier) is designed to protect inhabitants from noise pollution by reducing outdoor noise pollution, for instance the noise of road or rail traffic. A noise barrier includes structural elements and acoustic elements, see image 1.

Generally, noise barriers have two acoustic specifications called sound insulation and sound absorption. Sound absorbing materials are the materials that will absorb and convert some or all of the sound into heat. While, sound insulation means preventing sound from transferring one side to another by reflecting the sound.

POLYVANTIS offers LEXAN™ polycarbonate sheet for acoustic elements with high performance in sound insulation.

## THE IMPORTANCE OF NOISE BARRIERS

The maximum suitable level of sound for human is 60 dB, which equals a normal conversation between two people standing at a distance of one meter. The pleasure environment's sound level can be around 30 dB. The sound level higher than 70 dB over a constant period of time can cause a stressful situation or annoyance, for example a washing machine or a dishwasher sound. Moreover, the noise above 85 dB can in a short time (for example, 5 minutes to 2 hours) or immediately damage human ears. For instance, on average, a motorcycle can have 95 dB of loudness, or a train horn has 100 dB of loudness.

It shows the necessity of noise barriers in today's world, as urbanization is increasing and the quality of life is being emphasized by local authorities. Transparent LEXAN™ sheet can reduce noise levels by 30 dB in average, which can make a considerable difference between a pleasant and unpleasant environment and makes it suitable to use in high traffic areas.

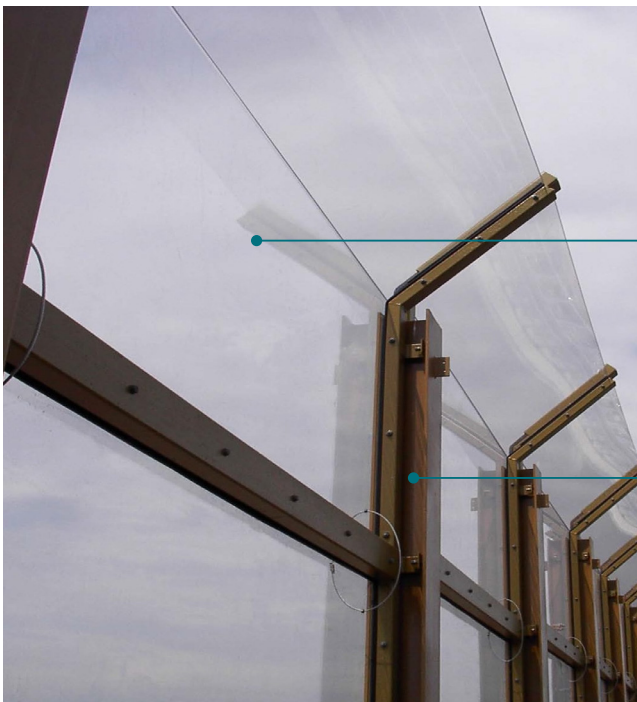

ACOUSTIC ELEMENT

STRUCTURAL ELEMENT

Image 1: Noise Barrier Elements



Noise Barriers, ENOC Fuel station, Dubai, UAE – With LEXAN™ EXELL™ D Opal white sheet

## NOISE BARRIERS STANDARDS

Most important required standards for performance measurement of Noise Barriers include (European standards):

### ACOUSTIC PERFORMANCES

**EN1793-1:** A laboratory method for measuring the sound absorption performance.

**EN1793-2:** A laboratory method for measuring the airborne sound insulation performance.

**EN1793-3:** Gives a normalized traffic noise spectrum for the evaluation and assessment of the acoustic performance

**ISO717-1:** Defines single-number quantities for airborne sound insulation in buildings and of building elements

### NON-ACOUSTIC PERFORMANCES

**EN1794-1:** Mechanical performance and stability requirements including: wind load and static load, self-weight, impact of stones, safety in collision, and dynamic load from snow clearance.

**EN1794-2:** General safety and environmental requirements including: risk of falling debris, environmental protection, means of escape in emergency, light reflection, and transparency.

**EN1794-3:** Reaction to fire - burning behaviour of noise reducing devices and classification.

## LEXAN™ SHEET ACOUSTIC ELEMENTS

LEXAN™ EXELL™D, LEXAN™ MARGARD™ and LEXAN™ EXTRITE™ sheet are transparent polycarbonate sheet materials, ideally suited for use in sound screens (as acoustic elements). Due to their unique properties these products makes them ideal for demanding sound screens and noise reduction barrier applications in urban, road, rail and airport environments. Proven in use throughout Europe, US and Pacific region, they carry our industry-leading ten year limited warranty against breakage.

In addition to the inherent characteristics of a polycarbonate material, LEXAN™ MARGARD™ and LEXAN™ EXTRITE™ sheet have a proprietary hard surface coating, on one or two sides, which provides a high level of resistance to abrasion and weathering.

The products are backed by a limited warranty against loss of light transmission, coating failure and breakage.

# PRODUCT SOLUTIONS

## POLYVANTIS PRODUCT OFFERINGS FOR NOISE BARRIER APPLICATIONS

### LEXAN™ EXELL™ D Sheet:

This virtually unbreakable, transparent, polycarbonate materials under LEXAN™ sheet portfolio come with UV protection on one or both sides and provide remarkable clarity - even after many years of intense sunlight and weather extremes.

### LEXAN™ EXTRITE™ Sheet:

A transparent polycarbonate solid sheet with proprietary UV protection on both sides offering excellent weathering properties. With its excellent impact and scratch resistance it is a perfect candidate for a wide variety of building and construction and other glazing applications.

To the new protective layer, the material is fulfilling a demand for areas where abrasion and scratch resistance and weathering is important. The intrinsic properties of LEXAN™ polycarbonate combined with a one side protective layer results in improved abrasion, chemical and UV resistance.

### LEXAN™ MARGARD™ Sheet:

Lightweight, coated MARGARD™ Sheet products are highly resistant to abrasion, chemicals and have excellent weathering properties. LEXAN™ MARGARD™ Coated Sheet not only has the usual properties of a polycarbonate material, it also has a proprietary hard surface coating on one or both sides. This makes it highly resistant to abrasion and weathering. Available clear or bronze-tinted, products come with a limited warranty against loss of light transmission, coating failure and breakage.

## LEXAN™ SHEET ACOUSTIC PERFORMANCE

LEXAN™ sheet is tested according the current global standards for acoustic and non-acoustic elements. Test data demonstrates that LEXAN™ EXELL™ D, LEXAN™ MARGARD™ and LEXAN™ EXTRITE™ sheet match the acoustic performance of traditional materials, but with a significantly thinner LEXAN™ polycarbonate screen. The sound insulation test results is provided in table 1:

Sheet thickness (mm)	Noise reduction (dB)	
	ISO 717-1 (R <sub>W</sub> ) <sup>1</sup>	EN 1793-2 (DL <sub>R</sub> ) <sup>2</sup>
8	32	28
9.5	33	29
12	34	30
15	35	32

1 Noise Reduction Inside building

2 Noise Reduction Specifically for traffic noise

Table 1: Noise Reduction Test Results





# NON-ACOUSTIC PERFORMANCE



## EXTREMELY HIGH IMPACT RESISTANCE

Virtually unbreakable and resistant to abrasion – 250 times stronger than glass, retaining exceptionally high impact resistance, minimizing the risk of damage by accidents or vandalism (Figure 1).



## EXCELLENT OPTICAL CLARITY

High transparency / 87 - 90%



## UV PROTECTED FOR LONG-TERM DURABILITY

With superior UV protection on both sides, these sheets are highly resistant to yellowing and loss of performance due to weathering, as covered in the limited warranty conditions of all products.



## MINIMIZING THE RISK OF FALLEN DEBRIS

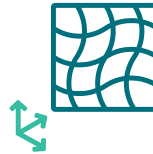

## MAXIMUM NORMAL WIND LOAD AND STATIC (VERTICAL) LOAD



## FIRE RESISTANCE

LEXAN™ sheet does not contribute to spread of flames and achieves high ratings in the major European fire performance tests. They will not contribute to the spread of fire and generation of toxic gases (see table 2 and 3).



## DYNAMIC LOAD FROM SNOW CLEARANCE

Falling dart impact test 2.3 kg. steel dart 25.4 mm diameter dip

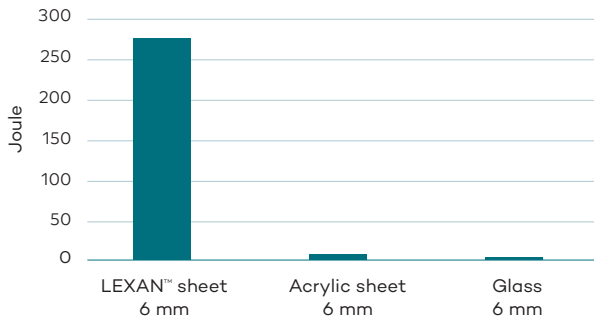

Figure 1. Impact Resistance

A	Non-combustible materials	Concrete, steel
B	Very limited contribution to fire	LEXAN™ Standard Polycarbonate Sheet
C	Limited contribution to fire	Plasterboard
D	Medium contribution to fire	Untreated wood
E	High contribution to fire	Acrylic
F	Very easily flammable	Gasoline

Table 2. Europe EN 13501 classification

Class A	Flame Spread of 0-25, Smoke Developed ≤450	LEXAN™ EXELL™-D FR Sheet
Class B	Flame Spread of 26-75, Smoke Developed ≤450	LEXAN™ Standard Polycarbonate Sheet
Class C	Flame Spread of 76-200, Smoke Developed ≤450	Wood
Un-rated	Smoke Developed >450. Not allowed in the International Building Code for Interior Finishing	Acrylic sheet

Table 3. ASTM E84 classification

Please, scan or click the QR code to watch the impact and fire performance video.



Impact performance video



Fire performance video

## BENEFICIAL FEATURES



### EXCELLENT CLEANING PERFORMANCE

Withstands repeated cleaning with common hospital cleaning agents. Gently wash the sheet with a solution of mild soap and lukewarm water, using a soft, grid-free cloth or sponge to loosen any dirt or grime.



### HIGH CHEMICAL RESISTANCE

LEXAN™ solid sheet products have a high resistance to most moderate chemicals. For a complete list of compatible cleaners, please contact your POLYVANTIS representative.



### ANTI-GRAFFITI



### THERMOFORMABLE



### 2 SIDES ABRASION RESISTANT



### 10-15 YEARS LIMITED "NO BREAK" WARRANTY



### EASE OF INSTALLATION AND HANDLING



### LIGHTWEIGHT (SEE TABLE 4)

Material	Thickness (mm)	Surface Density (Kg/m <sup>2</sup> )	Noise Reduction (dB)
Polycarbonate	8	10 – 14	30 – 33
Light Concrete	100	161	36
Dense Concrete	100	244	40
Brick	150	288	40
Panels Polyester film backed by Metal sheet	50 – 125	20 – 30	30 – 47

Table 4: Material comparison – Weight & Noise reduction

Please, scan or click the QR code to access all technical aspects of our product offering.



LEXAN™ EXELL™ -D Sheet



LEXAN™ EXTRITE™ Sheet



LEXAN™ MARGARD™ Sheet

## PRODUCT COMPARISON

LEXAN™ MARGARD™ sheet provides enhanced resistance to oils, paints and other fluids, making it ideal for use in close proximity with motor vehicles, or in areas prone to graffiti attack (the advantage of MARGARD sheet against EXTRITE™ and EXELL™D sheet).

Unique surface coating of MARGARD and EXTRITE™ sheet provides high resistance to abrasion, to minimize damage by frequent contact or cleaning.

Features	EXELL™ D Sheet	EXTRITE™ Sheet	MARGARD™ Sheet
Excellent Sound Insulation	•	•	•
Impact Resistance	•	•	•
Long-term UV Protected	•	•	•
Fire Resistance	•	•	•
Transparency	•	•	•
Scratch (Abrasion) Resistance	–	•	•
Anti-Graffiti	–	–	•
Chemical Resistance	•	•	•
Thermoformability	•	•	•

Table 5: Comparison between different degrees of LEXAN™ polycarbonate sheet

## PRODUCT AVAILABILITY

Grade	Standard Size <sup>1</sup> (mm)	Thickness (mm)	Colours <sup>1</sup>
LEXAN EXELL-D Sheet	2050 width	8, 9.5, 12, 15	112 (clear)
			5109 (bronze)
			713 (grey)
			GN8A081T Solar Control IR green
LEXAN EXTRITE Sheet	2050 width	8, 9.5, 12, 15	112 (clear)
			5109 (bronze)
			WH4D348O (opal white)
			GY6E575T (grey)
LEXAN MARGARD Sheet	2000 width	8, 9.5, 12, 15	112 (clear)
			5109 (bronze)
			713 (grey)
			GN8A081T Solar Control IR green

<sup>1</sup> Other colors, thicknesses & sizes available upon request.

Table 6: Product availability

# PROJECT REFERENCES







# PROPOSED CONCEPTS & INSTALLATION

## FREEDOM OF DESIGN WITH LEXAN™ POLYCARBONATE SHEET

LEXAN™ sheet is light, easy to handle, and bendable. The sheet can be bent along its top edge. This eliminates the need for top profiles, making installation simpler. Sheet deflection, sound reflection and field of vision are also enhanced in this way.

### Curve

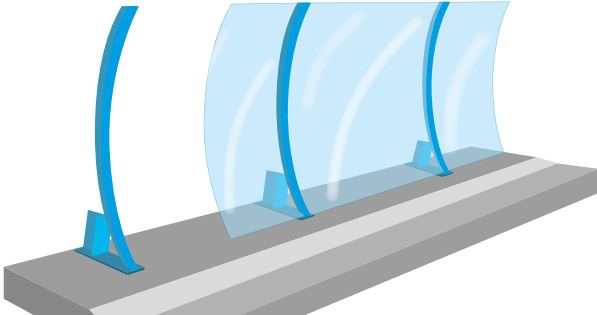

### Hook

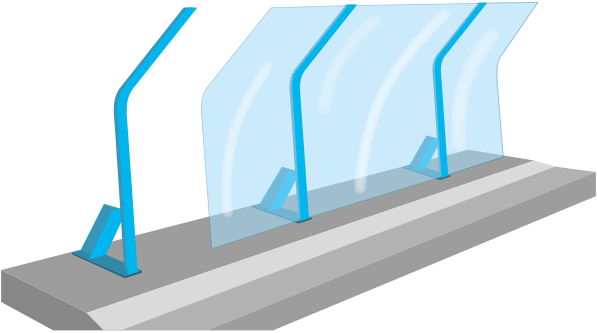

### Wave

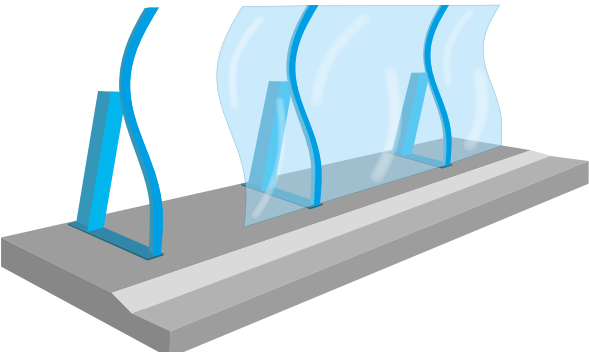

# DESIGN CONCEPTS

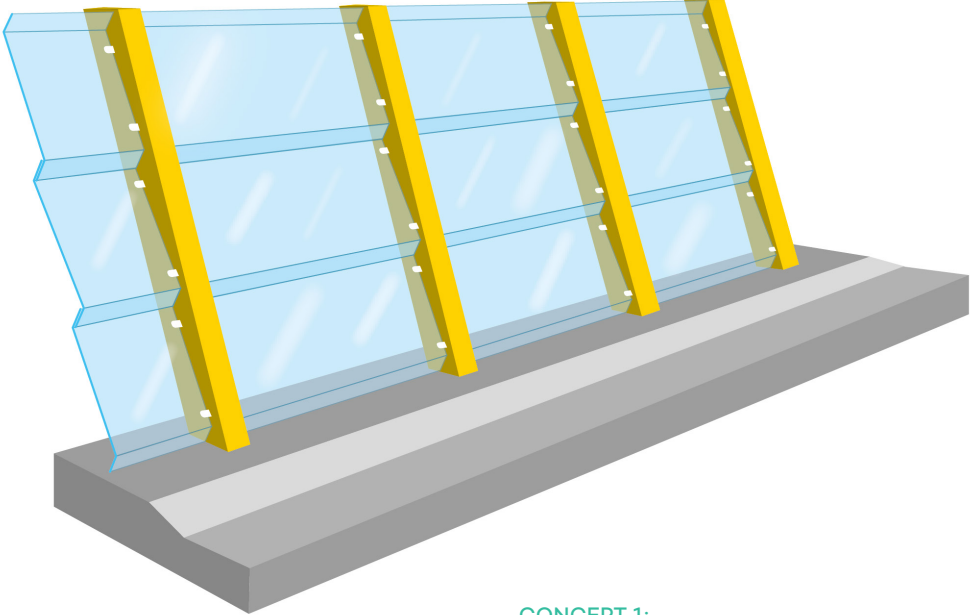

**CONCEPT 1:**  
1 Side clamped sheet  
1 Line bend unclamped sheet side

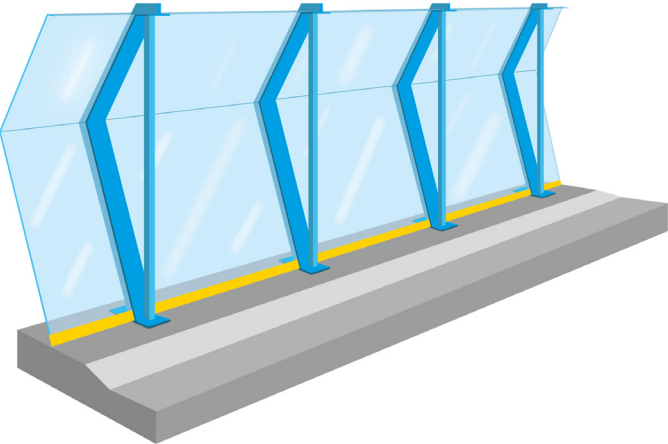

**CONCEPT 2:**  
3 Sides clamped sheet  
2 Line bend unclamped sheet side

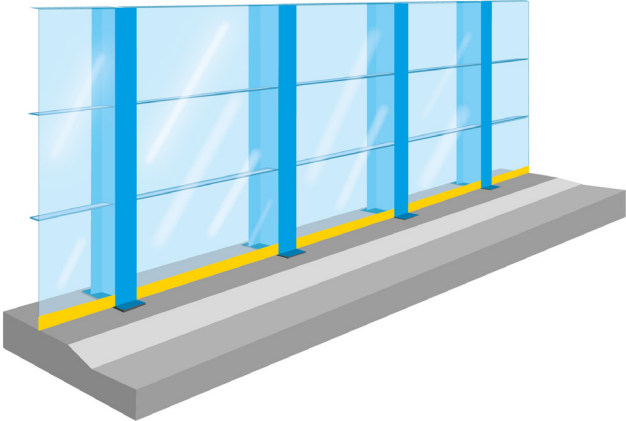

**CONCEPT 3:**  
Line bend "U" shaped LEXAN™ Sheet panels  
Pilled panels with bolted panel flanges



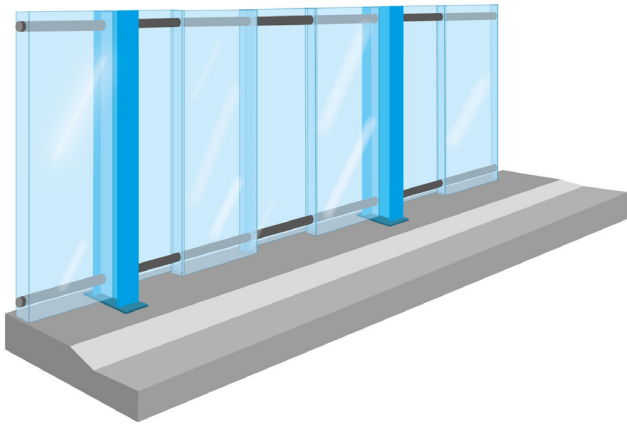

**CONCEPT 4:**  
Vertical stacked line bended "U" shaped  
LEXAN™ Sheet panels

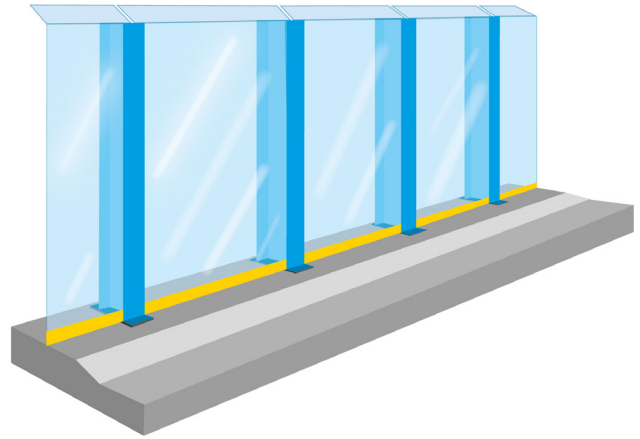

**CONCEPT 5:**  
4 Sides clamped LEXAN Sheet panels

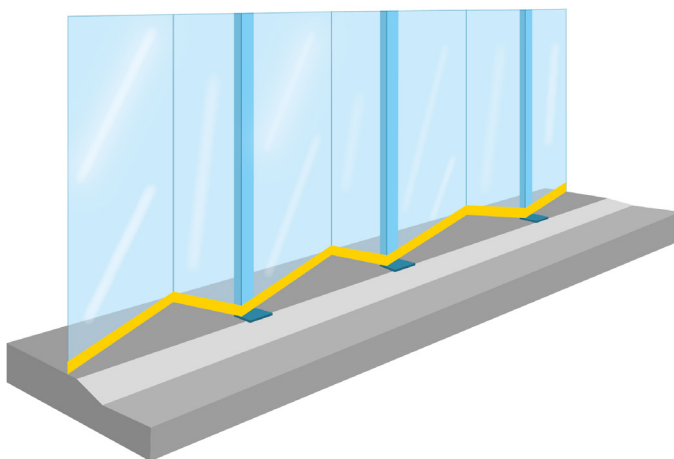

**CONCEPT 6:**  
3 Sides clamped sheet vertical line bending

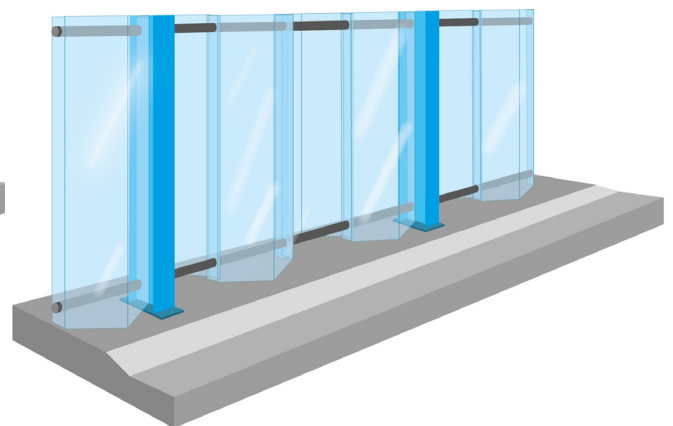

**CONCEPT 7:**  
Vertical stacked line bended "U" shaped  
LEXAN Sheet panels

# INSTALLATION GUIDELINES

## LEXAN™ sheet fixing proposals to vertical support profile

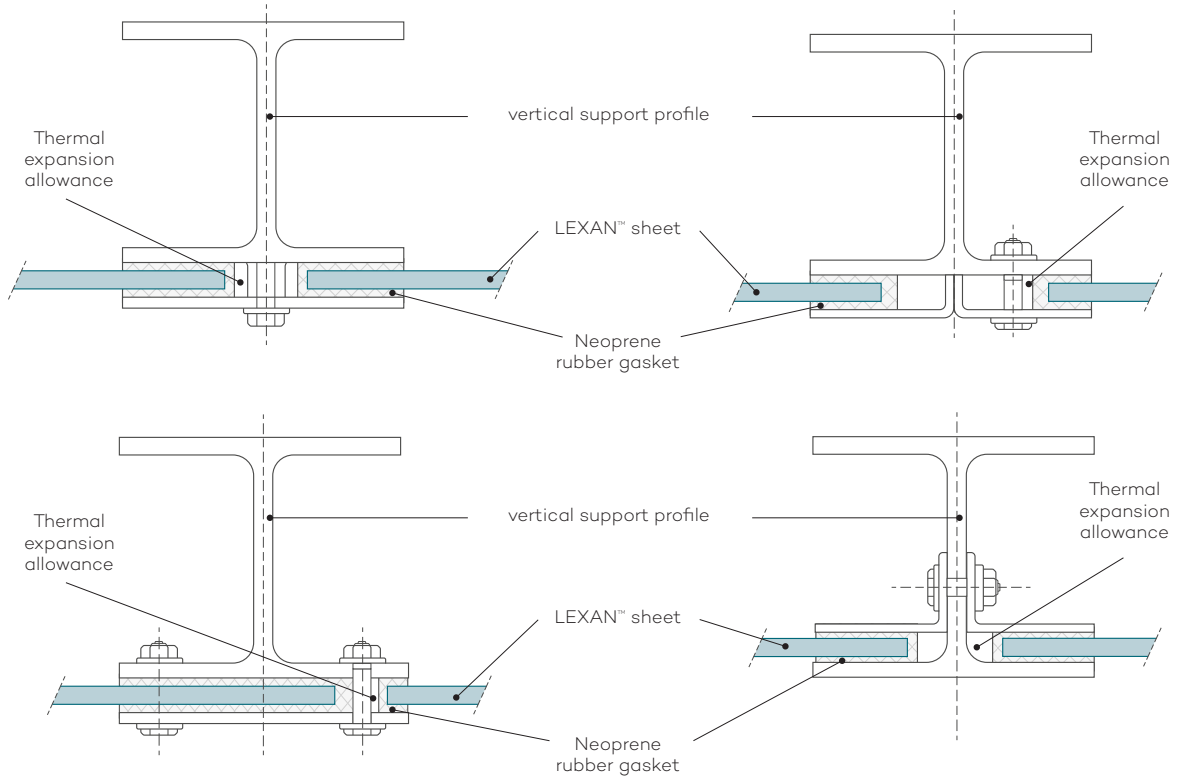

## LEXAN™ sheet fixing proposals to top, middle, and bottom profile

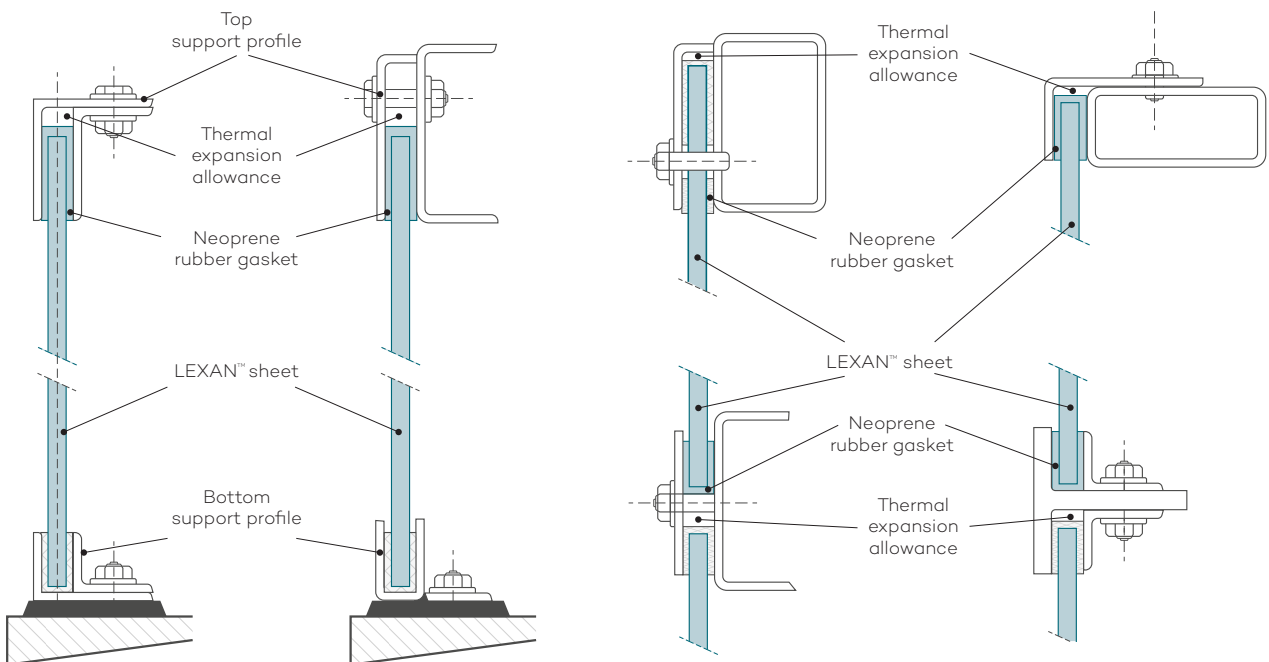

# GLOBAL COMPANY WITH LOCAL SERVICES & SUPPLY



**POLYVANTIS IS COMMITTED TO ITS CUSTOMERS AROUND THE WORLD WITH A PORTFOLIO OF POLYCARBONATE FILM & SHEET MATERIALS, APPLICATION SUPPORT AND WORLDWIDE SERVICES.**

POLYVANTIS operates a worldwide network of sales, distribution, research, manufacturing and technical service facilities. POLYVANTIS serves customers around the world in a broad spectrum of industries and applications. POLYVANTIS offers global cross-business

resources and expertise, and from its network of technical centers the company provides a variety of services. These include hands-on engineering and technical support that extends from selecting the right material to characterization of mechanical, thermal, UV/heat aging data, advanced light measurements and optical

modeling to part design and installation guidelines. The company also offers a local team, complete supply chain, and distribution organization to ensure a reliable source of materials to its customers wherever their manufacturing site is located.

**POLYVANTIS**

[www.polyvantis.com](http://www.polyvantis.com)



**LEXAN™** Tough,  
Virtually  
Unbreakable  
POLYCARBONATE FILM & SHEET